

Alice Jepson Theatre

Modlin Center for the Arts
University of Richmond



TECHNICAL PACKET

Revised August 2024

SECTION 2 – FACILITIES

SECTION 2.1 – FRONT OF HOUSE

TOTAL CAPACITY 576

Orchestra Level - 444

Balcony Level (Continental Style) - 132

Standing Room Only 50

THRUST/ORCHESTRA PIT: 514

Orchestra Level - 388

Balcony Level (Continental Style) - 132

Standing Room Only - 50

ADDITIONAL INFORMATION

576 maximum seating

514 without rows AAA-DDD

536 without rows AAA-CCC

486 without rows AAA-DDD and Voms

62 pit seating

NOTE:

Accessible seating available (See **FIGURE 2.1-1** on the next page)

Assistive Listening Systems are available (Sennheiser infrared system with approx. 20 headset units).

Distance between 1st row of seats (row A with rows AAA-DDD removed) and Main Drape at Center Line is 18'-8".

Distance between 1st row of seats (row AAA) and Main Drape at Center Line is 6'-9".

Distance between Main Drape and last row of seats is 44'-0".

Public Restrooms located in Main Lobby of complex near Box Office, adjacent to Main Atrium.

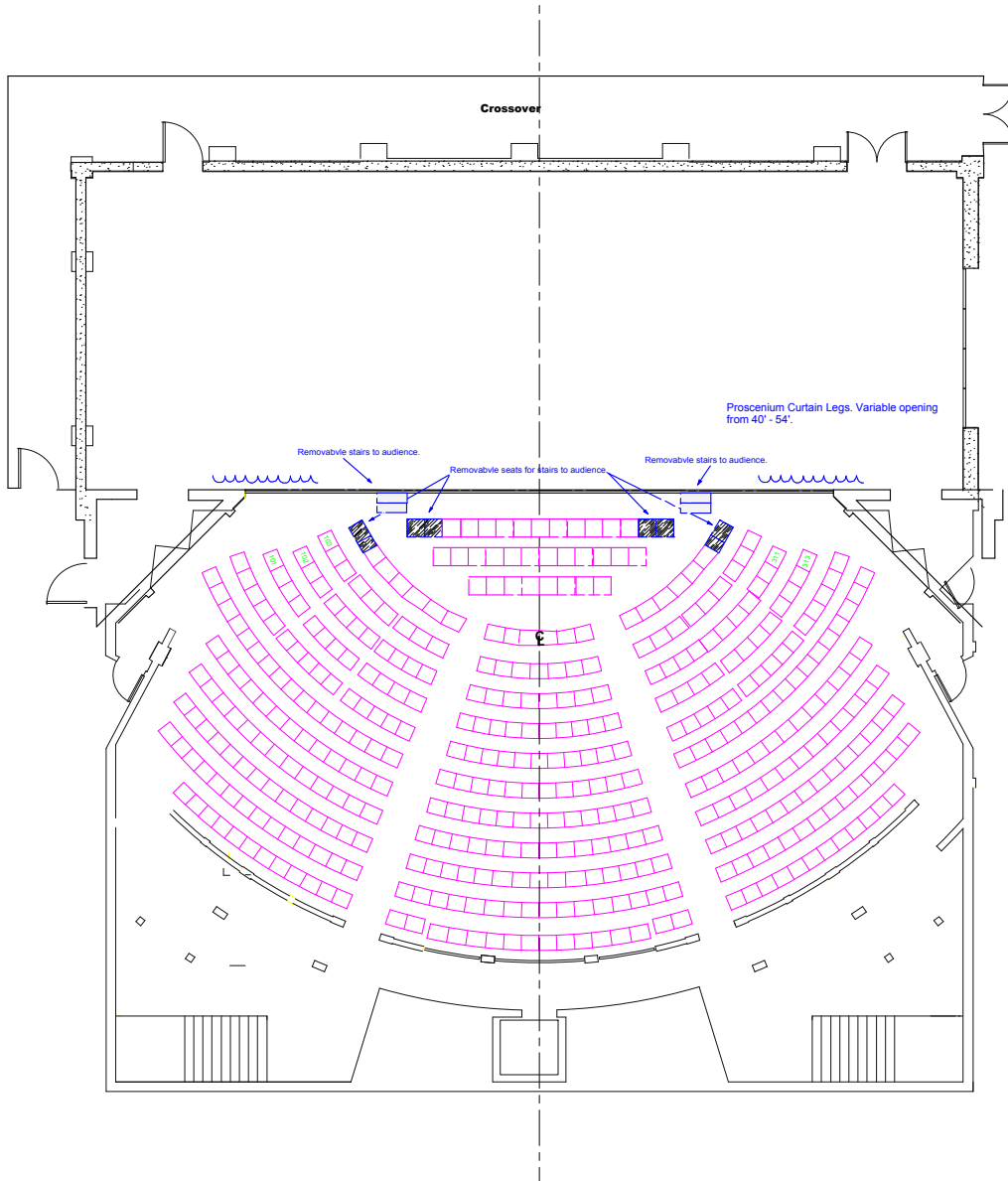

FIGURE 2.1-1 – Alice Jepson Theatre Seating Diagram

Section 2.2 - Backstage Facilities

All facilities are on the same level, one floor down from the stage level of Jepson Theatre. Accessible by elevator and stairs immediately adjacent to loading dock and stage entrance.

Dressing Rooms

One (1) Male and one (1) Female chorus-style dressing room equipped with make-up counters, make-up mirrors with integrated lighting, chairs, full length wall mirrors, hooks, and individually keyed lockable storage; may accommodate up to 15 people in each room. Bathrooms are ensuite to dressing rooms and not accessible to the public.

One (1) auxiliary room which may be configured to function as additional dressing room space, instrument storage, office space, costume prep, etc. This space has no integrated make-up counters or mirrors and no ensuite plumbing.

Bathrooms

Men's Dressing Room Bathroom: two (2) sinks with mirror, two (2) toilet stalls, one (1) urinal, three (3) showers.

Women's Dressing Room Bathroom: three (3) sinks with mirror, three (3) toilet stalls, three (3) showers.

Staff/Crew Bathroom: one (1) toilet and one (1) sink located off of the Green Room kitchen area.

*Staff/Crew Bathroom is handicap accessible. Both Men's and Women's Dressing Room Bathrooms equipped with handicap accessible toilets and shower stalls.

Green Room

Large living area with sprung floor, cable TV and onstage monitor; two (2) sofas, eight (8) armchairs, assorted side/coffee tables/ottomans

Kitchen area with full-size refrigerator with water dispenser, sink, full-size dishwasher, ice machine, microwave, toaster; counter seating for four (4), modular bar-height table seating for up to six (6).

Production office for up to two (2) people with dedicated phone/ethernet ports

WiFi Internet Access

Guest internet access available across the University of Richmond on the VisitUR wifi network. Login instructions are posted in the Green Room.

Wardrobe

two (2) large capacity washing machines and dryers
one (1) iron and ironing board
one (1) industrial steamer
one (1) sewing machine; assorted hand sewing supplies also available
Rolling racks and hangers

SECTION 3 – STAGE INFORMATION

SECTION 3.1 – STAGE

PROSCENIUM OPENING

Width: 59'-0" **N.B.:** *Typical house masking to 46' Proscenium Opening*
Height: 25'-0"

OVERALL STAGE DIMENSIONS

Width: 88'-0" from SR Wall to SL Wall
Depth: 46'-6" from edge of Thrust Stage to back wall; Depth from plaster line: 32'0"
Grid Height: 60'-0" (floor to Grid)
Above Grid Height: 12'-6 1/2"
Off-stage Wings:
 SL: 12'-6", Proscenium to Wall; Height Clearance: 22'-6" (under Fly Gallery)
 SR: 12'-6", Proscenium to Fly Rail; Height Clearance: 22'-6" (under Fly Gallery Loading Rail)

DECK

Sprung Stage. Approximately 2/3 of the stage floor is trapped. Trap units are sprung as well.

On a 40" x 80" platform, there is a 68 lbs per square foot. Allowable concentrated load on 2'6" x 2'6" is 1838 lbs and on a 6" x 6" area 1200lbs. Max platform is 4000lbs with a .04 inch deflection.

Stage surface is painted, 1/4" tempered Masonite. Nails and screws permitted.

Subsurface 11'0" DS of Rear Wall and Offstage: 1/4" tempered Masonite on plywood on 2x4 on face with plywood underlayment. 2x4's on 1/4" rubber pads. poured cement.

CROSSOVER

Crossover is located upstage of rear wall of Stage House. Access gained to crossover US left and right through doors, as well as hallway offstage left. Crossover permits entrances and exits to and from audience.

ORCHESTRA PIT/LIFT/THRUST

Lift

Depth at Center: 10'-0"
Depth SL/SR: 3'-4"
Width US: 26'-8" Width DS: 13'-6"
14 to 16 musicians on Lift
Maximum Static Load: 34,500 lbs.
Maximum Lift Load: 11,500 lbs.
Speed: 6 f/s.

Pit size at lowest level approximately 33'0"x26'8"; room for a maximum of 35-40 musicians at lowest level.

Pit Height at lowest level, 11'9" below stage level

NOTE: When orchestra lift is at stage height, stage is in Thrust configuration.

LOAD-IN FACILITIES

Loading Door is located in Scene Shop adjacent to Theatre, separated by hallway.

Loading Door Width: 10'-0", Height: 9'-0"

Loading Dock Height: 32 1/2". Dock will allow 2 trucks/trailers to be unloaded while at dock at same time.
Dock is at stage level.

NOTE: 53'-0" trailer is a very tight fit maneuvering UR campus streets and parking lot.

There is a hydraulic platform located in the loading bay to assist with non-typical loading situations.

A 24'-0" wide x 20'-0" high pocket door is located SL, to allow loading from shop/dock through hallway.
Freight elevator located in scene shop.

Door measures 4'-0"x7'-0"

Cab measures 5'-6" x 8'-0"; diagonally 9'-6"

Elevator will access Basement/Pit Level, Stage Level and Technical Galleries.

Genie Lifts available.

30'-0" platform height. 36'-0" working height. Model #AWP-30S.

19'-0" platform height. 25'-0" working height.

SECTION 3.2 – FLY SYSTEM (SEE ATTACHED LINESSET SCHEDULE)

FLY SYSTEM + RAIL

Type:

Single Purchase Arbors with 3/4" Dacron Doublebraid
31 Linesets with 6 lines per set.
Last Lineset @ 30'3" US of Plaster Line

Location of Fly Rail:

Fly Controls located Stage Right, on deck.
1st Loading Rail located off Technical Gallery at 22'-6" from stage floor
2nd Loading Rail accessible via ladder Stage Right at 57'-0" from stage floor

Maximum Working Height:

57'-0"

Minimum Working Height:

3'-0"

Maximum Capacity per Batten:

1700 lbs. Approximately 10,000 to 20,000 lbs of spare weight available

Length of Battens:

69'-0".

All pipes fitted with pipe extensions to allow pipe to be breasted to pin rails.

Battens are 1-1/2" schedule 40 Steel pipe.

Cyclorama batten Length: 72'-0".

Hemp Lines not available.

GRID

Hanging Points for motors or other hung scenery are available in the wells or on the grid itself

Well locations have a maximum 2000lb load limit

Grid locations have a 1000lb load limit

*Note: See Load diagrams **figure 6.4***

SOFT GOODS

Grand Drape: pleated 50% fullness, maroon velour, 2 panel, guillotine only

Blackout Drops:

1 Drop, flat, 20 oz. IFR Velour, 2 panel, 36'-0" x 29'-0" guillotine and traveling.

1 Drop, flat, 20 oz. IFR Velour, 1 panel, 60'-0" x 29'-0" guillotine only.

Legs:

6 sets, flat, 20 oz. IFR Velour, 15'-0" x 29'-0"

Borders:

5, flat, 20 oz. IFR Velour, 65'-0" x 8'-0"

White Scrim:

1@ IFR Sharkstooth, 60'-0" wide x 30'-0" high

Black Scrim:

2@ IFR Sharkstooth, 60'-0" wide x 30'-0" high

Cyclorama:

IFR Filled Leno, White, 60'-0" wide x 30'-0" high

NOTE: While we include a typical lineset schedule with this packet, some of our soft goods are moveable. Also, we have no dedicated electrics. Any batten without soft goods may be used as an electric pipe.

SECTION 3.3 – LINESET SCHEDULE

Alice Jepson Theater Lineset Schedule								
NOTE: Hanging Goods in BOLD type are non-moveable.								
Lineset	Distance	House Typical	Trim	Notes	Show Hang	Trim	Notes	Suggested
Pro Pipe	0	LEG		Open At 46'				Leg 46'
1	1'-7"	BORDER						
2	2'-3"	MAIN DRAPE						
3	2'-11"							
4	3'-7"	1E	26'					
5	4'-11"							
6	5'-7"							
7	6'-3"	BORDER						
8	6'-11"	LEG		Open At 44'				
9	8'-11"							
10	9'-7"							
11	10'-3"	2E	26'					
12	10'-11"							
13	12'-11"	BORDER						
14	13'-7"	LEG		Open At 44'				
15	14'-3"							
16	14'-11"							
17	16'-11"	3E	26'					
18	17'-7"							
19	18'-3"	BORDER						
20	18'-11"	LEG		Open At 44'				
21	20'-11"							
22	21'-7"							
23	22'-3"	4E	26'					
24	23'-7"							
25	24'-11"	BORDER						
26	26'-3"	LEG		Open At 44'				
27	26'11"	Black Scrim						
28	27'7"							
29	28'11"	Full Black Traveler		Travel/Guillotine				
30	29'-7"	LED Cyc Light						
31	30'-3"	Cyclorama						

FIGURE 3.3-1 – Lineset Schedule (editable version on website)

SECTION 4 – LIGHTING SYSTEM + ELECTRICS

CONTROL

ETC ION XE 12K
Primary Position Control Area Rear of Balcony
Secondary Position Rear of Orchestra, under Balcony
tertiary Position 3rd Floor Tech Booth

DIMMERS

294 Strand CD80SV, located in 4 racks, Updated Processors in 2013.
Rack location in Mechanical Closet accessible from stairwell adjacent to theatre. 26 of these dimmers dedicated as Houselights and Stage Worklights.
Several Non-Dim Cards for LED Unit Power

CIRCUITS

268 circuits with 20 amp, 3-pin stage connectors.
Several circuit box locations equipped with breakouts:

Grid Level

Stage Right: DS circuits 256-267; US circuits 244-255
Stage Left: DS circuits 184-207; MS circuits 208-231; US circuits 220-243

Proscenium

Stage Right: 13-15
Stage Left: 10-12

Pinrail (Mid Rail)

Stage Right Pinrail: 88-117
Stage Left Pinrail: 1-6, 40-63
SR circuits 178-183
SL circuits 172-177

US Wall

SR - 28-39
SL - 16-27

Catwalks

Proscenium: 88-93 HR; 94-99 HL
1st Catwalk: 100-105 HR; 106-111 HC; 112-117 HL
2nd Catwalk: 118-123 HR; 124-129 HRC; 130-135 HC; 136-141 HLC; 142-147 HL

Technical Gallery

64-75 HR Wall
148-159 HR Booth Rail
160-171 HL Booth Rail
76-87 HL Wall

HR Box Position: 40-45

HL Box Position: 58-63

HR Alcove: 40-45

HL Alcove: 58-63

Balcony Rail Position: 46-57

Trap Room

SL - 1-6
SR - 7-9

DESIGNATED ELECTRICS: - Any batten without soft goods may be used as an electric pipe (See **FIG 3.3-1**)

COMPANY SWITCH

IF COMPANY SWITCH IS REQUIRED, PLEASE ADVANCE THROUGH PRODUCTION TEAM.

US Left: Two (2), 400 amp, 120/208 VAC, 3-phase, 4 wire, Colortran Model #6-9007

DS Left: One (1), 100 amp, 120/208 VAC, 3-phase, 4 wire, Colortran Model #6-9008

ADDITIONAL POWER

IF ADDITIONAL POWER IS REQUIRED, PLEASE ADVANCE THROUGH PRODUCTION TEAM.

Proscenium Catwalk:

60 amp, 3-phase, 240V Disconnect Strip

one (1) 100 amp, 3-phase, 4 wire disconnect; one (1) 50 amp, 2 pole/1 pole, 3-phase, 4 wire disconnect;

one (1) 20 amp, 3 pole Disconnect;

one (1) 20 amp, 1 pole disconnect

Grid:

two (2) strips, one (1) SR and one (1) SL

one (1) 100 amp, 3-phase, 4 wire disconnect

one (1) 50 amp, 2 pole/1 pole, 3-phase, 4 wire disconnect

one (1) 20 amp, 3 pole Disconnect

one (1) 20 amp, 1 pole Disconnect

Tech Gallery Booth:

one (1) 60 amp, 3-phase, 240V Disconnect

SECTION 4.2 – LIGHTING INVENTORY

	LEKO/ERS	
ETC SOURCE 4 LEKO BODY	150	575W
ETC SOURCE 4 BARRELS		
10 DEG	4	
19 DEG	33	
26 DEG	57	
36 DEG	86	
50 DEG	32	
COLORTRAN 50/50 ERS		
20 DEG	8	600W
30 DEG	55	600W
40 DEG	20	600W
SELECON PACIFIC ERS		
90 DEG	2	750W
	FRESNEL/PARS	
ETC COLORSOURCE PARS DB (MFL/WFL)	21	90W
ETC SOURCE 4 PARS	7 W/ FULL LENS KIT	575W
ALTMAN PAR 64 (NSP/MFL/WFL)	60	1000W
ALTMAN 8" FRESNEL	50	1000W
	CYCLORAMA LIGHTING	
PHILIPS SL660 RGBW	6' 12	750W
ALTMAN SKY CYC 3	3 CELL 6	1000W
L&E MINI STRIPS MR-16	8', 4 CIR 4	750W
	MOVING LIGHTS	
VARI LITE 1000 TS	3	1000W
BLIZZARD FLURRY Z	6	
	ACCESSORIES (MORE AVAILABLE ON REQUEST)	
6.25" TOPHATS	8	
6.25" HALFHATS	16	
6.25" COLOR EXTENDERS	23	
7.5" BARN DOORS	4	
7.5" TOPHATS	12	

SECTION 4.3 – AJT GROUND PLAN

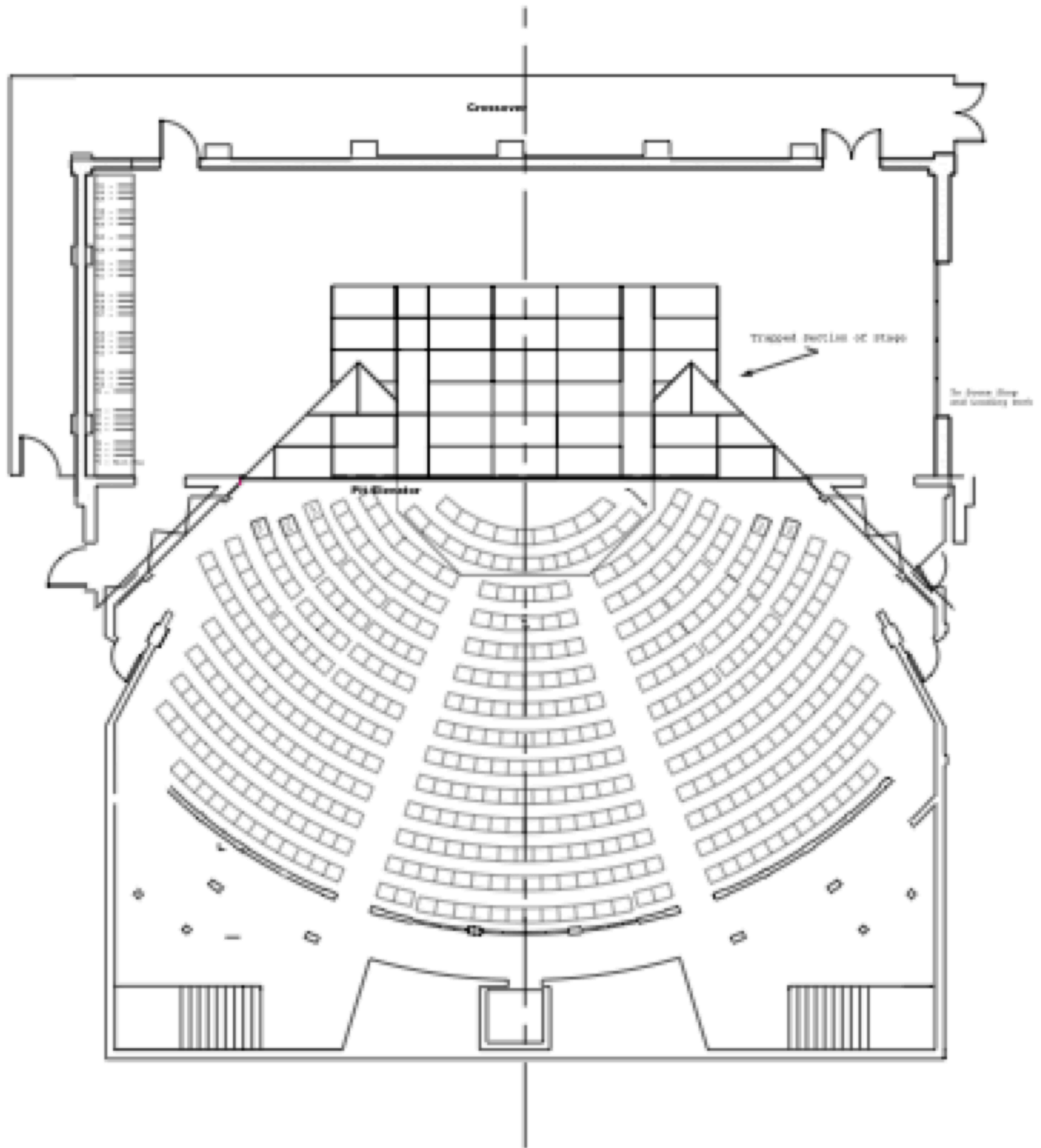

FIGURE 4.3-1 – Alice Jepson Theatre Ground Plan

FOR VECTORWORKS LIGHTPLOT AND SECTION FILES, SEE WEBSITE

SECTION 4.4 – AJT SECTION

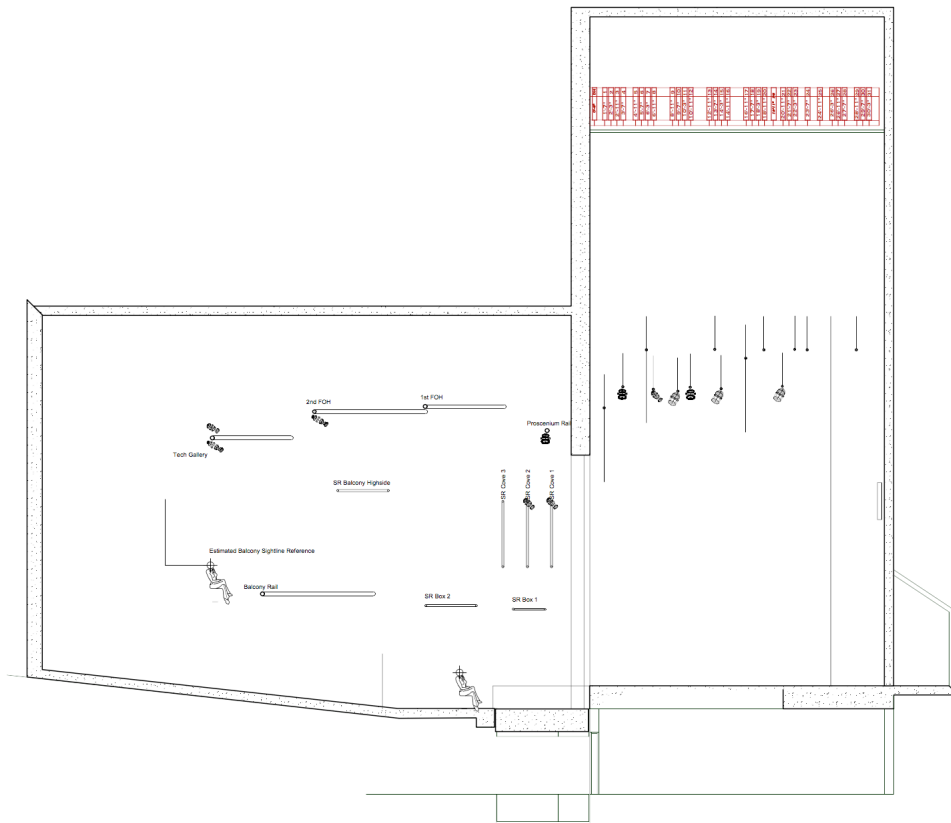

FIGURE 4.4-1 – Alice Jepson Theatre Section

FOR VECTORWORKS LIGHTPLOT AND SECTION FILES, SEE WEBSITE

SECTION 5 – AUDIO AND COMMUNICATIONS

Alice Jepson Theater is equipped with an excellent sound system. (24) D&B Y12 array speakers are flown in three eight box arrays, LCR; five D&B VSubs are located under the stage.

These are driven by a Yamaha CL5 console with Dante transport. There is a Rio 3224 and Rio 1608 at FOH, alongside two portable Rio 3224s and an Ri8 onstage. There is additional connectivity in our booth and amp room.

Our array is supplemented with Innovox HLA Stage Lip speakers as front fills, R/H ICLive columnar arrays as proscenium fills, and QSC flush mount ceiling speakers for under balcony fills.

SECTION 5.1 – HOUSE SYSTEM

MIX POSITION CONSOLE + I/O

1	Yamaha	CL5	Mix Position	72x24x8 Digital Audio Console
1	Yamaha	Rio 3224	Mix Position	32 Channel Rio
1	Yamaha	PW800W	Mix Position	Console Redundant PSU
1	Apple	Mac Mini	Mix Position	Media / Playback
1	Lenovo	ThinkCenter	Mix Position	Dante Control
1	Packedge	SW24	Mix Position	24 port switch for Dante Network
1	Shure	ULXD4Q	Mix Position	Wireless Microphone Receiver
1	RF Venue	DFINDISTRO 04	Mix Position	Wireless Mic Distribution Amplifier
1	Yamaha	CL1	Portable Onstage	48x24x8 Digital Audio Console (Monitors)
2	Yamaha	Rio 3224	Portable Onstage	32 Channel Rio
1	Yamaha	Rio 1608	Portable Onstage	16 Channel Rio
1	Yamaha	Ri8	Portable Onstage	8 Channel Inpput

SPEAKERS

24	D&B	Y12	L/C/R Arrays	Array Speaker
5	D&B	V-Sub	Under Stage	Subwoofer
2	R/H	ICL-F-RN	Proscenium L/R	Iconyx Array Speaker
5	Innovox	HLA Stage-Lip	Front of Stage	Front Fill Speaker
7	QSC	AD-C821R	Under Balcony	Flush Mount Ceiling Speaker
4	Meyer	UPM2P	Balcony Fill	Active Speaker
4	D&B	E4	Portable	Speaker
4	Galaxy	HotSpot	Portable	2 active / 2 Passive
2	JBL	Control 5	Portable	Speaker
2	JBL	Control 5	Wall Mounted	Control Room Speaker
4	Meyer	UPM2P	Portable	Active Speaker w/ Rigging Hardware
3	Meyer	UPM2P	Portable	Active Speaker

AMPS

8	D&B	30D	Rack Room	Amplifer
1	D&B	10D	Rack Room	Amplifer
8	QSC	PLX 2502	Rack Room	Amplifier
1	QSC	CXD4.2Q	Rack Room	Amplifier
1	Klark Technic	DN 360	Booth	Analog Equalizer
1	Tascam	CD-RW900SL	Booth	Compact Disc Player and Recorder
1	Yamaha	Rio 3224	Booth	32 Channel Rio
1	Yamaha	Ro8	Booth	8 Channel analog out

SECTION 5.2 – MICROPHONES & ACCESSORIES

4	Crown	PCC 160	Portable	Floor Mic
4	Countryman	B3	Portable	Lav Mic with Shure Connector
3	Countryman	E6	Portable	Cocoa Omni Directional Earset Microphone,TA4F Connector
2	Countryman	E6	Portable	Beige Omni Directional Earset Microphone,TA4F Connector
7	Countryman	E6	Portable	Tan Omni Directional Earset Microphone,TA4F Connector
3	Sennheiser	MD421 II	Portable	Dynamic Microphone
6	Shure	WL50	Portable	Condenser Lav with Shure Connector
2	Shure	ULX D4Q	Portable	Quad Wireless Receiver
8	Shure	ULX D2	Portable	Handheld Transmitter with Beta58 Capsule
8	Shure	ULX	Portable	Bodypack Transmitter with TA4F Connector
3	Shure	SM57	Portable	Dynamic Microphone
2	Shure	Beta57	Portable	Dynamic Microphone
5	Shure	Beta58	Portable	Dynamic Microphone
1	Shure	Beta52a	Portable	Dynamic Microphone
2	Shure	SM81	Portable	Unidirectional Condenser Microphone
6	Shure	MX202B	Portable	Hanging Condenser Microphone
12	DPA	4060	Portable	Lav Mic w/Micro Dot Connector. Shure Adapters available.

DI

4	Countryman	DT85	Portable
4	Horizon	Straightline	Portable
2	Radial	Pro 48	Portable
2	Whirlwind	PCDI	Portable

Assortment of Microphone Stands (AKG, Atlas, K&G, etc)
Numerous turnarounds and adaptors

SECTION 5.3 – IN-HOUSE COMMUNICATION + ALS

1	Clearcom		Booth	4 Channel Rack Mounted Com Brain
10	Clearcom	RS-701	Portable	Beltpack
5	Clearcom	RS-702	Portable	Beltpack
6	Clearcom	CC-26K-X4	Portable	Headset Featherweight
4	Clearcom	CC-400-X4	Portable	Headset Double Ear
10	Clearcom	CC-300-X4	Portable	Headset Single Ear
2	Custom		Portable	Stage Manager Rack with Video, Com, and Paging
1	Listen	LS-71-072	Booth	Advanced Level IV RF System
20	Listen	LR-5200-072	House Manager Closet	DSP RF Receiver
20	Listen	LA-401	House Manager Closet	Ear Speaker
4	Listen	LA-166	House Manager Closet	Neck Loop

SECTION 6 – TECHNICAL DRAWINGS

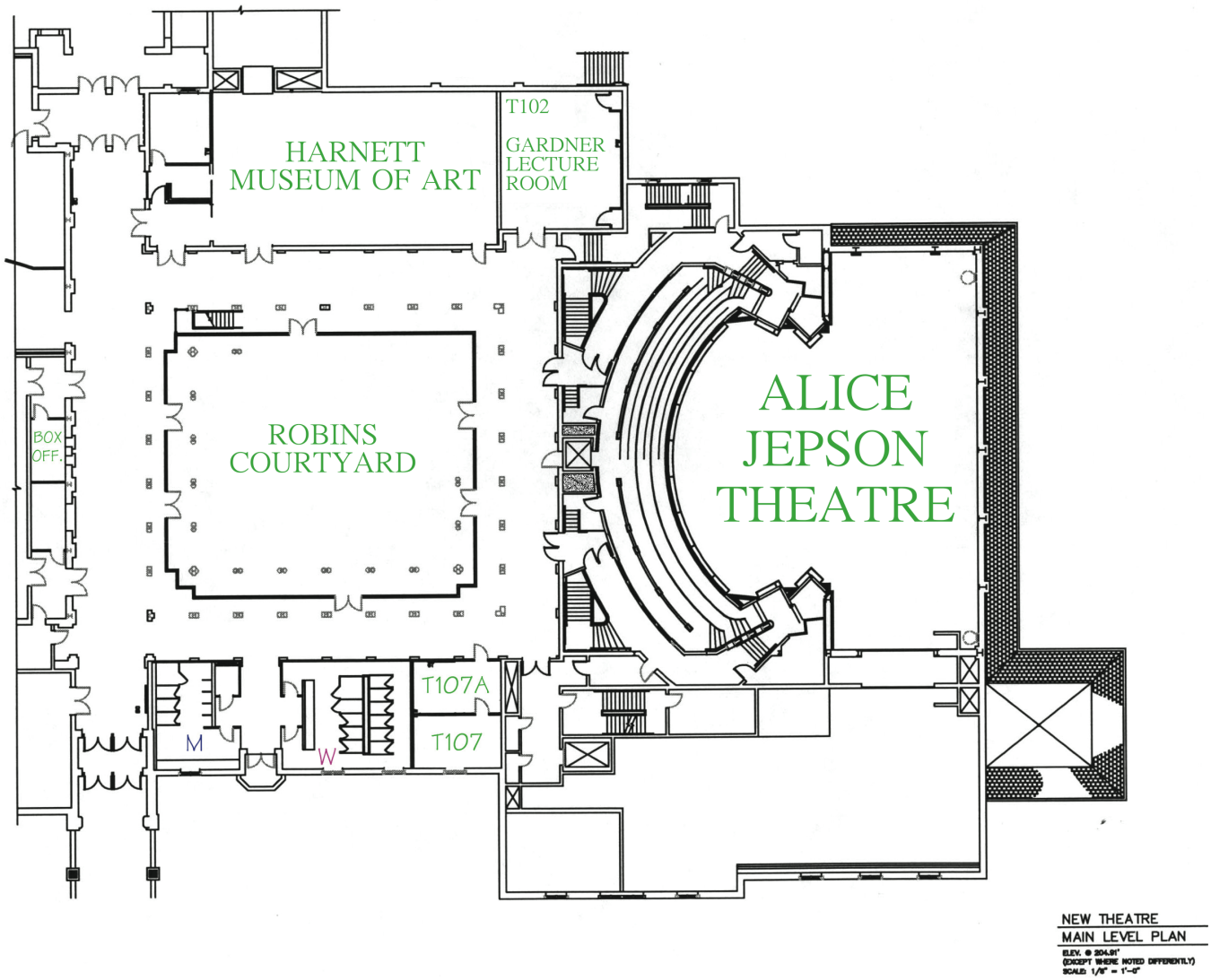
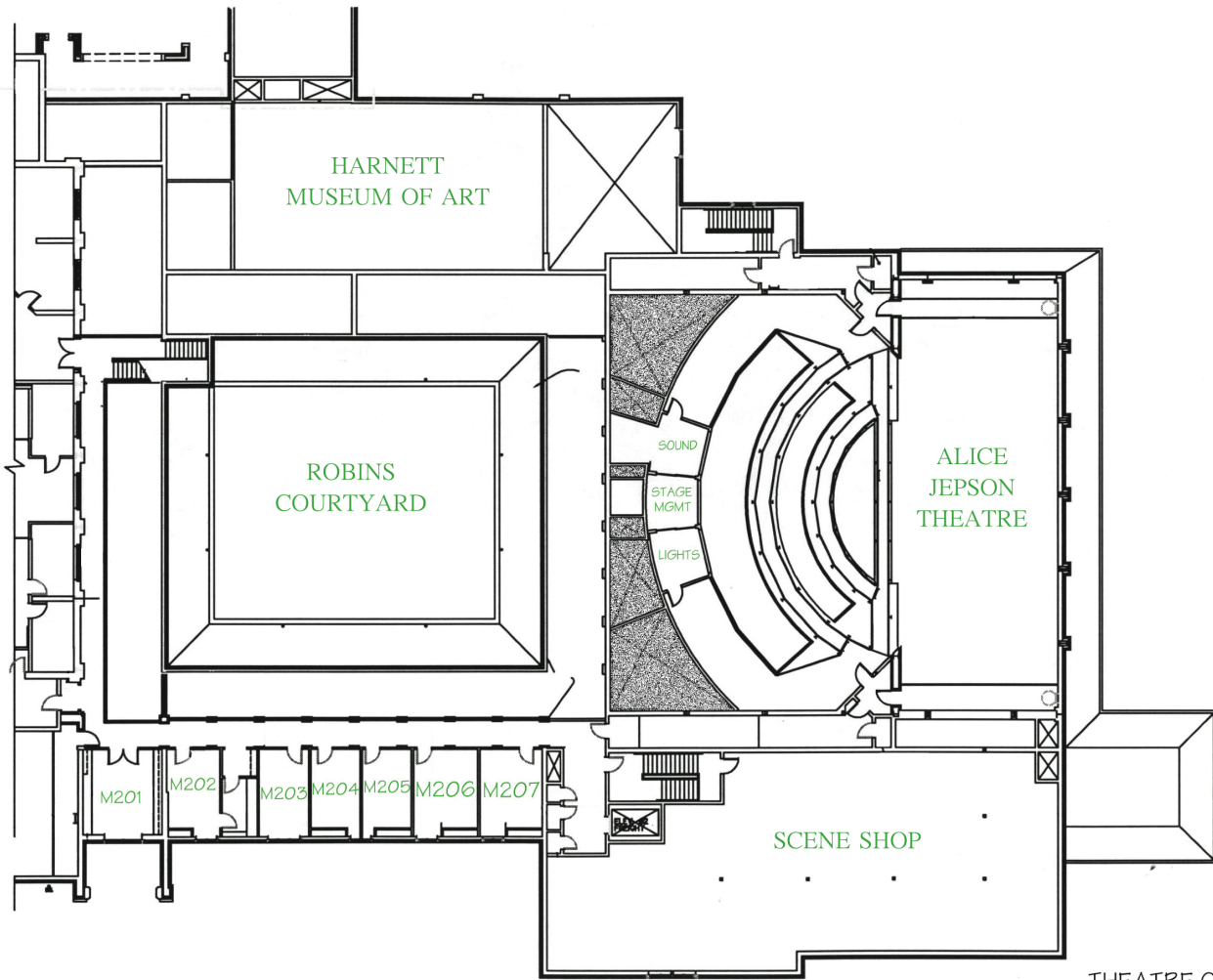

FIGURE 6-1 – Alice Jepson Theatre Main Level



THEATRE COMPLEX
 SECOND LEVEL PLAN
 ELEV. @ 214.72'
 (EXCEPT WHERE NOTED OTHERWISE)
 SCALE: 1/8" = 1'-0"

FIGURE 6-2 – Alice Jepson Theatre Second Level

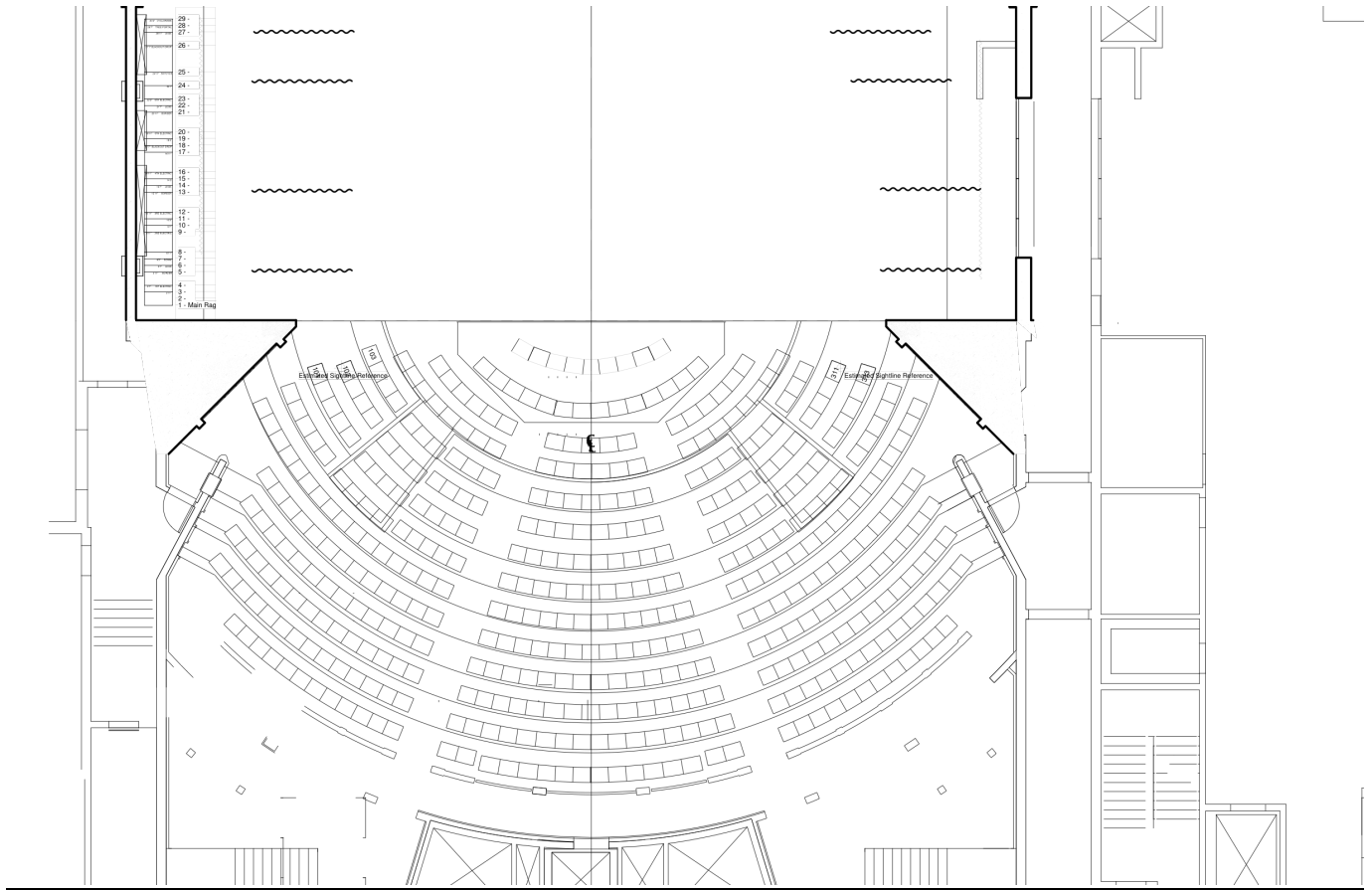
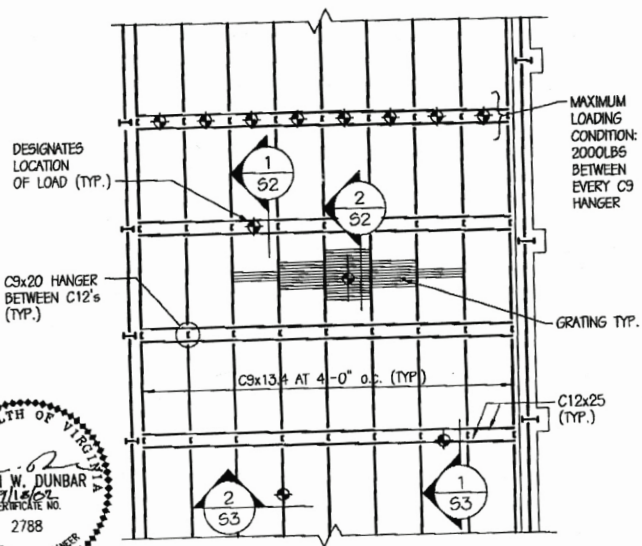

FIGURE 6-3 – Alice Jepson Theatre Stage And Orchestra Level



STAGE LOADING PLATFORM GRID FRAMING PLAN

1/8" = 1'-0"

◆ LOCATION OF LOADS INDICATE TYPICAL CONDITIONS. LOADS CAN BE LOCATED AT SIMILAR LOCATIONS ANYWHERE ALONG THE LENGTH OF THE CHANNEL, OR ANYWHERE ON THE GRATING.

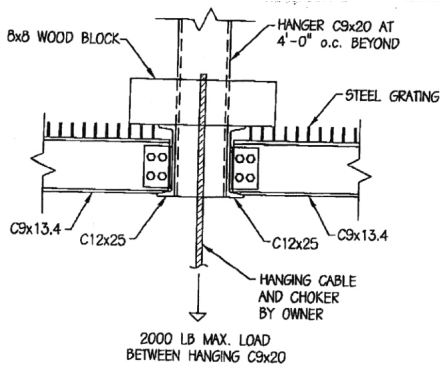

SECTION 1
3/4" = 1'-0"

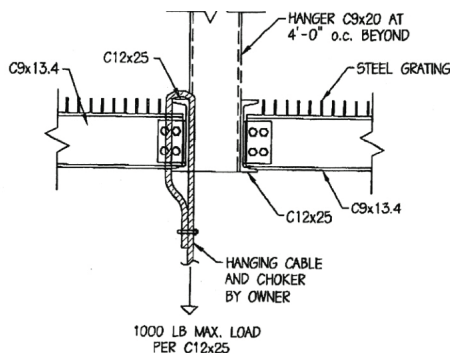

SECTION 1
3/4" = 1'-0"

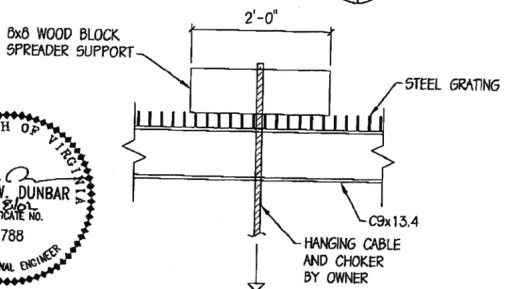

SECTION 2
3/4" = 1'-0"

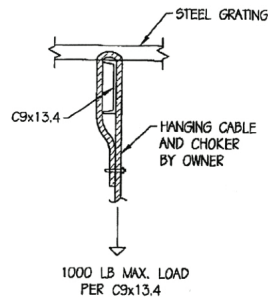

SECTION 2
3/4" = 1'-0"



FIGURE 6.4 JEPSON GRID LOADS

SECTION 7 – DIRECTIONS AND LOCAL INFO

ALICE JEPSON THEATRE, MODLIN CENTER FOR THE ARTS AT THE UNIVERSITY OF RICHMOND

GPS COORDINATES: 37.573550, -77.54270

50 Crenshaw Way, University of Richmond, VA 23173

SECTION 7.1 – DIRECTIONS

Please Note: The University has directional signage posted on I-95 and I-64: DO NOT FOLLOW THESE SIGNS! The directions listed above are the most direct route to the Modlin Center for the Arts.

FROM POINTS NORTH: (NEW YORK, BALTIMORE, PHILADELPHIA, WASHINGTON, DC)

- From Interstate 95, Take Exit #79 (Signs to I-64 West)
- Bear left onto I-195, following signage to SOUTH / Powhite Parkway.
- Follow I-195 2.3 miles to your second exit, "Cary Street / Grove Avenue"
- Stay straight off of the exit 2/10 mile, take a RIGHT at the traffic light, onto Cary Street Road (Route 147 – South)
- Take Cary Street 2.0 miles . At the 2nd traffic light, bear to the LEFT. (This will be through a Residential area, the Country Club of Virginia will be on your right after you go through the light)
- Cary Street turns into River Road at the traffic light. Go to the bottom of the hill, approx. 6/10 mile And bear to the right, immediately before the traffic intersection. (Staying on River Road)
- Go 7/10 mile on River Road and take your 2nd RIGHT, onto College Road. (At the top of the hill)
- Go 2/10mile on College Drive (Alumni House and President's Home will be on your right) to the Westhampton College / University of Richmond Gate. *Immediately after passing the Alumni Center, Bear to the RIGHT, through the gate.*
- Take your first RIGHT onto Crenshaw Way. Follow this road of a mile 3/10 mile and take a LEFT into Modlin Center parking lots The Modlin Center is at the end of this parking lot.
The loading dock is at the far right part of the building, at the lower end of the parking lot.
The Administrative Office is through the front door (at the sculpture), at the end of the right hallway, Room #T-107A

FROM POINTS SOUTH: (RALEIGH, CHARLOTTE, ATLANTA)

- From Interstate 95, Take Exit #79 (Signs to I-64 West)
- Bear left onto I-195, following signage to SOUTH / Powhite Parkway.
- Follow I-195 2.3 miles to your second exit, "Cary Street / Grove Avenue"
- Stay straight off of the exit 2/10 mile, take a RIGHT at the traffic light, onto Cary Street Road (Route 147 – South)
- Take Cary Street 2.0 miles. At the 2nd traffic light, bear to the LEFT. (This will be through a Residential area, the Country Club of Virginia will be on your right after you go through the light)
- Cary Street turns into River Road at the traffic light. Go to the bottom of the hill, approx. 6/10 mile And bear to the right, immediately before the traffic intersection. (Staying on River Road)
- Go 7/10 mile on River Road and take your 2nd RIGHT, onto College Road. (At the top of the hill)
- Go 2/10mile on College Drive (Alumni House and President's Home will be on your right) to the Westhampton College / University of Richmond Gate. *Immediately after passing the Alumni Center, Bear to the RIGHT, through the gate.*
- Take your first RIGHT onto Crenshaw Way. Follow this road of a mile 3/10 mile and take a LEFT into Modlin Center parking lots The Modlin Center is at the end of this parking lot.
The loading dock is at the far right part of the building, at the lower end of the parking lot.

The Administrative Office is through the front door (at the sculpture), at the end of the right hallway, Room #T-107A

FROM POINTS EAST (NORFOLK, WILLIAMSBURG):

- Follow I-64 until it merges with on I-95
- Exit to the right, getting onto I-95 – North (To Washington / I-64 West)
- From Interstate 95 Take Exit #79 (Also following Signs to I-64 West - Charlottesville)
- Bear left onto I-195 SOUTH / Powhite Parkway.
- Follow I-195 approx. 2.3 miles to your second exit, “Cary Street / Grove Avenue”
- Straight off of the exit .2 mile, take a right at the traffic light, onto Cary Street Road (Route 147 – South)
- Take Cary Street 2.0 miles. At the 2nd traffic light, bear to the LEFT. (This will be through a Residential area, the Country Club of Virginia will be on your right after you go through the light)
- Cary Street turns into River Road at the traffic light. Go to the bottom of the hill, approx. .6 miles And bear to the right, immediately before the traffic intersection. (Staying on River Road)
- Go 7/10 mile on River Road and take your 2nd RIGHT, onto College Road.
- Go 2/10 mile on College Drive (Alumni House and President’s Home will be on your right) to the Westhampton College / University of Richmond Gate. *Immediately* after passing the Alumni Center, bear to the RIGHT and enter the University’s campus through this gate.
- Take your first RIGHT onto Crenshaw Way. Follow this road of a mile 3/10 mile and take a LEFT into Modlin Center parking lots The Modlin Center is at the end of this parking lot.
The loading dock is at the far right part of the building, at the lower end of the parking lot.
The Administrative Office is through the front door (at the sculpture), at the end of the right hallway, Room #T-107A

FROM POINTS WEST: (CHARLOTTESVILLE, STAUNTON):

- From Interstate 64, take exit #186 (To Downtown I-195)
- Bear RIGHT onto I-195 SOUTH / Powhite Parkway.
- Follow I-195 2.3 miles to your second exit, “Cary Street / Grove Avenue”
- Straight off of the exit 2/10 mile, take a right at the traffic light, onto Cary Street Road (Route 147 – South)
- Take Cary Street 2.0 miles. At the 2nd traffic light, bear to the LEFT. (This will be through a residential area, the Country Club of Virginia will be on your right after you go through the light)
- Cary Street turns into River Road at the traffic light. Go to the bottom of the hill, approx. 6/10 mile and bear to the right, immediately before the traffic intersection. (Staying on River Road)
- Go 7/10 mile on River Road and take your 2nd RIGHT, onto College Road. (At the top of the hill)
- Go 2/10 mile on College Drive (Alumni House and President’s Home will be on your right) to the Westhampton College / University of Richmond Gate. *Immediately* after passing the Alumni Center, bear to the RIGHT and enter the University’s campus through this gate.
- Take your first RIGHT onto Crenshaw Way. Follow this road of a mile 3/10 mile and take a LEFT into Modlin Center parking lots The Modlin Center is at the end of this parking lot.
The loading dock is at the far right part of the building, at the lower end of the parking lot.
The Administrative Office is through the front door (at the sculpture), at the end of the right hallway, Room #T-107A

SECTION 7.2-CAMPUS MAP



Campus Map

	Accessible Parking		Campus Information
	Visitor Parking		Roads
	Building Numbers		Walkways
	Under Construction		Construction Zone



Locations

5 Boatwright Memorial Library.....D3	31 Special Programs Building.....C5
38 Booker Hall.....C4	28 Steam Plant.....D4
18 Brunet Hall.....D2	53 Student Activities Complex.....B4
36 Cannon Memorial Chapel.....D4	7 Thomas Hall.....D3
52 Carolle Weinstein International Center.....D2	4 Tyler Haynes Commons.....D4
13 Dennis Hall.....D2	UFA University Forest
10 Freeman Hall.....D2	Apartment.....C5, C6, D6
55/58 Gateway Village.....D5	23b Weinstein Center for Recreation and Wellness.....D2
35 Gotwald Center for the Sciences.....C4	8 Weinstein Hall.....D3
39 Gray Court.....C4	33 Westhampton Center.....C4
34 Haliman Center (dining hall).....C4	59 Westhampton Hall.....B4
49 Jepson Alumni Center.....A4	51 Whitehurst.....D3
17 Jepson Hall.....D2	37 Wilson Center.....D4
15 Keller Hall.....D2	9 Wood Hall.....C3
43 Keller Hall.....B4	
6 Lakewood Hall.....C3	
32 Lora Robins Court.....C5	
11 Marsh Hall.....C2	
3a Maryland Hall.....D3	
16 Milhiser Gymnasium.....D2	
50 Modlin Center for the Arts.....B5	
12 Moore Hall.....C2	
24 New Fraternity Row.....C1	
40 North Court.....B4	
22 Old Fraternity Row.....D1	
27 Physical Plant.....D5	
44 President's Home.....A5	
3c Puryear Hall.....D3	
30 Queally Center.....C5	
1a Queally Hall.....E2	
3b Richmond Hall.....D3	
23a Robins Center.....D1	
14 Robins Hall.....D2	
1 Robins School of Business.....E2	
2 Ryland Hall.....D3	
19 School of Law.....E2	
28 Service Building.....D4	
42 South Court.....B4	

Places to Note

30 Admission and Financial Aid (Undergraduates).....C5
4 Bookstore.....D4
49 Botomley House.....A4
38 Camp Concert Hall.....C4
4 Career Services.....D4
30 Career Services - Employer Development.....C5
50 Hammett Museum of Art and Hammett Print Study Center.....B5
8 Human Resources.....D3
17 Jepson School of Leadership Studies.....D2
5 Lora Robins Gallery of Design from Nature.....D3
31 Public Safety and Student Health Center.....C5
51 Richmond College Dean's Office.....D3
1 Robins School of Business.....E2
5 School of Arts and Sciences.....D3
19 School of Law.....E2
31 School of Professional and Continuing Studies.....C5
33 Thalhimer Guest Cottage.....C4
5 Virginia Baptist Historical Society.....D3
33 Westhampton College Dean's Office.....C4

SECTION 7.3 – RICHMOND AREA INFORMATION

LOCAL HOSPITALS

Bon Secours Richmond Health System: St Mary's Hospital

5901 Bremono Road (2.2 miles from campus)
Emergency Room Entrance corner of Libbie Avenue & Monument Avenue
General (804) 285-2001 / Emergency (804) 281-8230

Henrico Doctors' Hospital

1602 Skipwith Road (2.6 miles from campus)
General (804) 289-4500 / Emergency (804) 330-2273

VCU Medical -Trauma Center (Level 1 Trauma Center)

401 North 12th Street (8.2 miles from campus)
General (804) 828-9000 / Emergency (804) 828-9151
Trauma (804) 828-7748

LOCAL HARDWARE STORES

Home Depot, 6501 West Broad Street, (804) 289-6020 (3.6 miles from campus)

Ace Hardware, 423 North Ridge Road, (804) 288-1262 (1.4 miles from campus)

LOCAL RENTAL HOUSE

Backstage Inc., 310 West Broad Street, (804) 644-1433 (7.0 miles from campus)

LOCAL FABRIC / NOTIONS STORES

Hancock Fabrics, 8051 West Broad Street, (804) 270-4903 (4.7 miles from campus)

JoAnn Fabric and Crafts, 8032 West Broad Street, (804) 270-0442 (4.8 miles from campus)

LOCAL GROCERY STORES

Ellwood Thompson's Natural Market, 4 North Thompson St., (804) 359-7525 (4.6 miles from campus)

Kroger, 3507 Cary Street, (804) 358-5399 (4.7 miles from campus)

LOCAL DRY CLEANERS/LAUNDRY FACILITIES

Westhampton Cleaners and Laundry, 314 Libbie Avenue, (804) 282-2755 (2 miles from campus)

Moizelles Cleaners and Launderer, 401 North 1st Street, (804) 643-0331 (7.5 miles from campus)

Hand Craft Cleaners, 5705 Patterson Avenue, (804) 285-3336 (2.5 miles from campus)

DENTIST

Dean R. Garfield, 5500 Monument Avenue, (804) 282-4646 (4.8 miles from campus)

Patricia A. Moss, 6714 Patterson Avenue, (804) 282-3197 (3.9 miles from campus)

ORTHOPEDIC SURGEON

Dr. Kenneth R. Zaslov, 7650 East Parham Road, (804) 270-1305 (7.9 miles from campus)

CHIROPRACTOR

Dr. Andrew J. Melchert, 6010 W. Broad Street, (804) 282-0403 (3.5 miles from campus)

For additional information, contact the Artist Services Office at (804) 287-6607.